

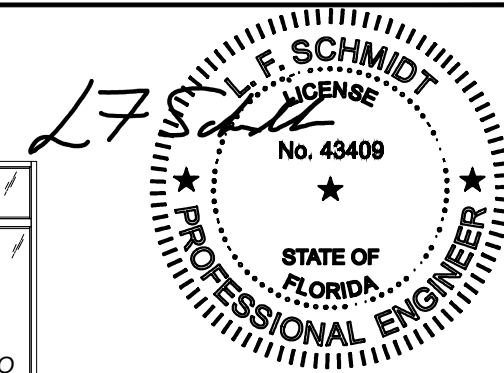

**"VERIS V3" GLAZED ALUMINUM PIVOT DOOR  
SINGLE w/ or w/out SIDELITE(S)  
w/ TRANSOM  
OUTSWING  
"IMPACT"**

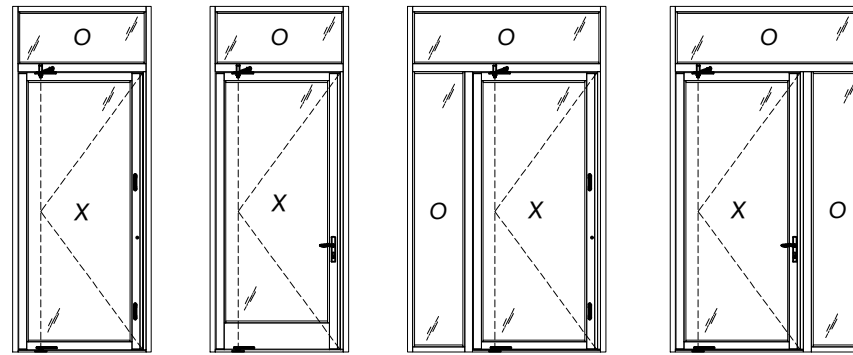

This item has been digitally signed and sealed by L. F. Schmidt, P.E. on the date adjacent to the seal. Printed copies of this document are not considered signed and sealed and the signature must be verified on any electronic copies.

THIS PRODUCT APPROVAL IS VALID ONLY FOR THE STATE OF FLORIDA

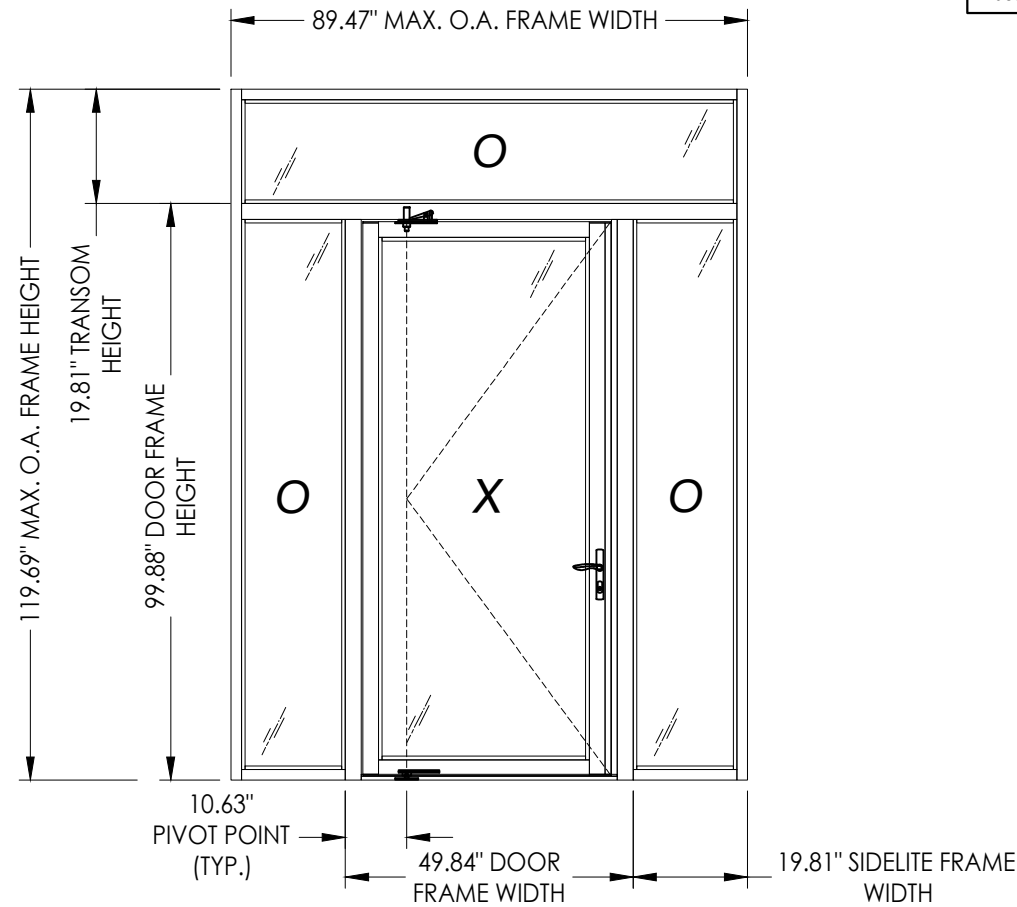

GENERAL NOTES

1. This product has been evaluated and is in compliance with the 8th Edition (2023) Florida Building Code (FBC) structural requirements excluding the "High Velocity Hurricane Zone" (HVHZ).
2. Product anchors shall be as listed and spaced as shown on details. Anchor embedment to base material shall be beyond wall dressing or stucco.
3. When used in areas requiring wind borne debris protection this product complies with FBC Sections 1609.1.2 & R301.2.1.2 and does not require an impact resistant covering. This product meets missile level "D" and includes Wind Zone 4 as defined in ASTM E1996 and FBC Sections 1609.1.2.2 & R301.2.1.2.1.
4. For 2x stud framing construction, anchoring of these units shall be the same as that shown for 2x buck masonry construction.
5. Site conditions that deviate from the details of this drawing require further engineering analysis by a licensed engineer or registered architect.

**TABLE OF CONTENTS**

SHEET #	DESCRIPTION
1	Typical Elevations, Design Pressures & General Notes
2	Door, Sidelite & Transom Panels & Glazing Details
3	Elevations
4	Horizontal & Vertical Cross Sections (2X Buck)
5	Horizontal Cross Sections (2X Buck)
6	Horizontal & Vertical Cross Sections (1X Buck)
7	Horizontal & Vertical Cross Sections (Direct to Masonry)
8	Horizontal Cross Sections
9	Vertical Cross Sections
10	Buck Anchoring
11	Frame Anchoring
12	Bill of Materials & Components

CONFIGURATION	MAX. FRAME DIMENSION	DOOR MAX. D.L.O.	SIDLITE MAX. D.L.O.	TRANSOM MAX. D.L.O.	DESIGN PRESSURE (PSF)	
					POSITIVE	NEGATIVE
$\frac{O}{X}$	47.97" x 119.69"	35.25" X 89.25"	N/A	43.09" X 16.75"	+50.0	-50.0
$\frac{O}{OX}$ or $\frac{O}{XO}$	68.72" x 119.69"	35.25" X 89.25"	16.75" X 94.06"	63.84" X 16.75"	+50.0	-50.0
$\frac{O}{OXO}$	89.47" x 119.69"	35.25" X 89.25"	16.75" X 94.06"	84.59" X 16.75"	+50.0	-50.0

Documents Prepared By:  
Lyndon F. Schmidt  
P.E. No. 43409

*RW*  
BUILDING CONSULTANTS, INC.  
P.O. Box 230, Valrico, FL 33595  
Phone No.: 813.659.9197  
FBPE Registry No. 9813

PRODUCT: THERMA TRU  
PART OR ASSEMBLY: TYPICAL ELEVATION, DESIGN PRESSURES & GENERAL NOTES

NO.	DATE	BY

DATE: 2/07/24  
SCALE: N.T.S.  
DWG. BY: LFS  
CHK. BY: RW  
DRAWING NO.: FL-46173.7  
SHEET 1 OF 12

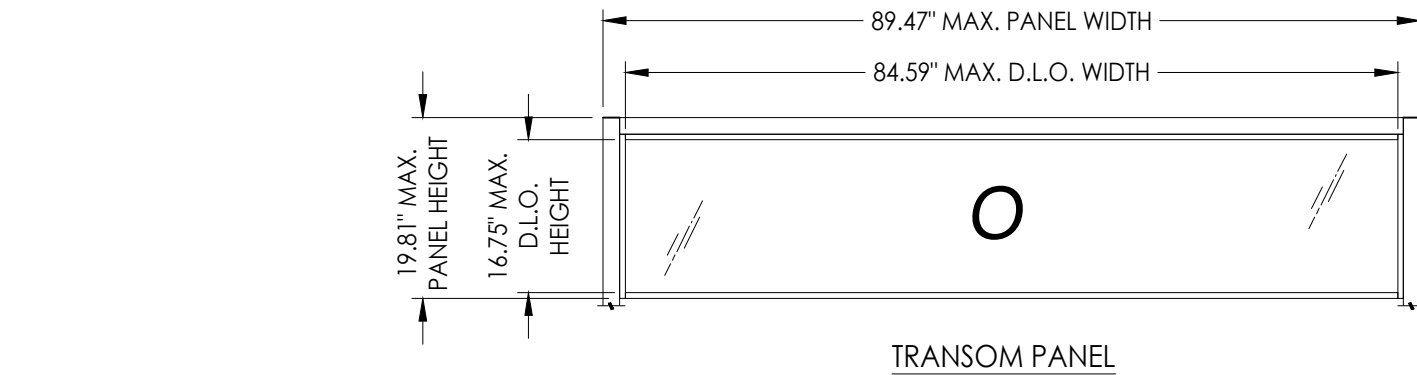

TRANSOM PANEL

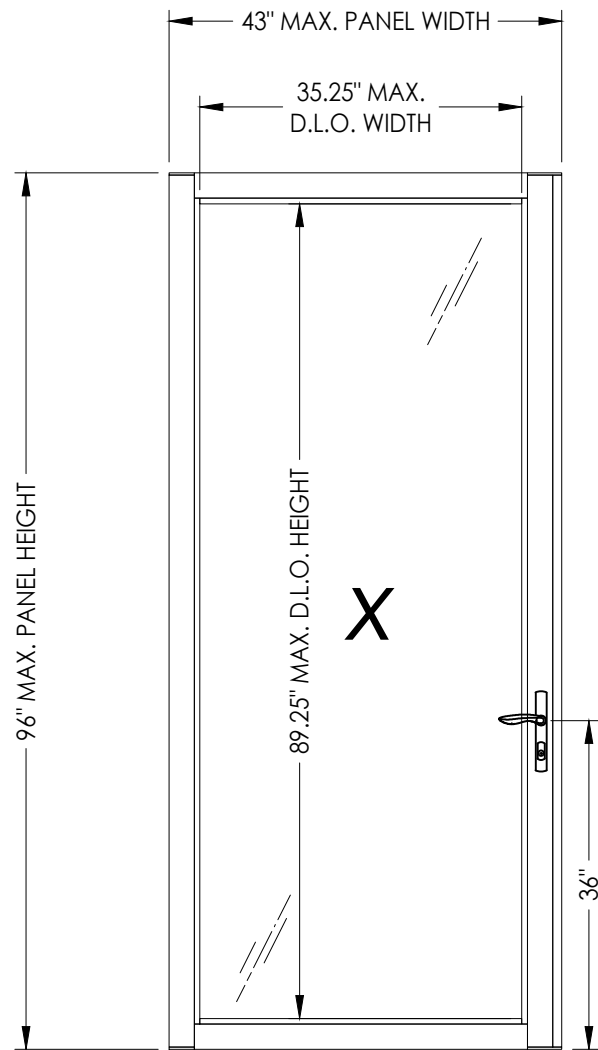

DOOR PANEL

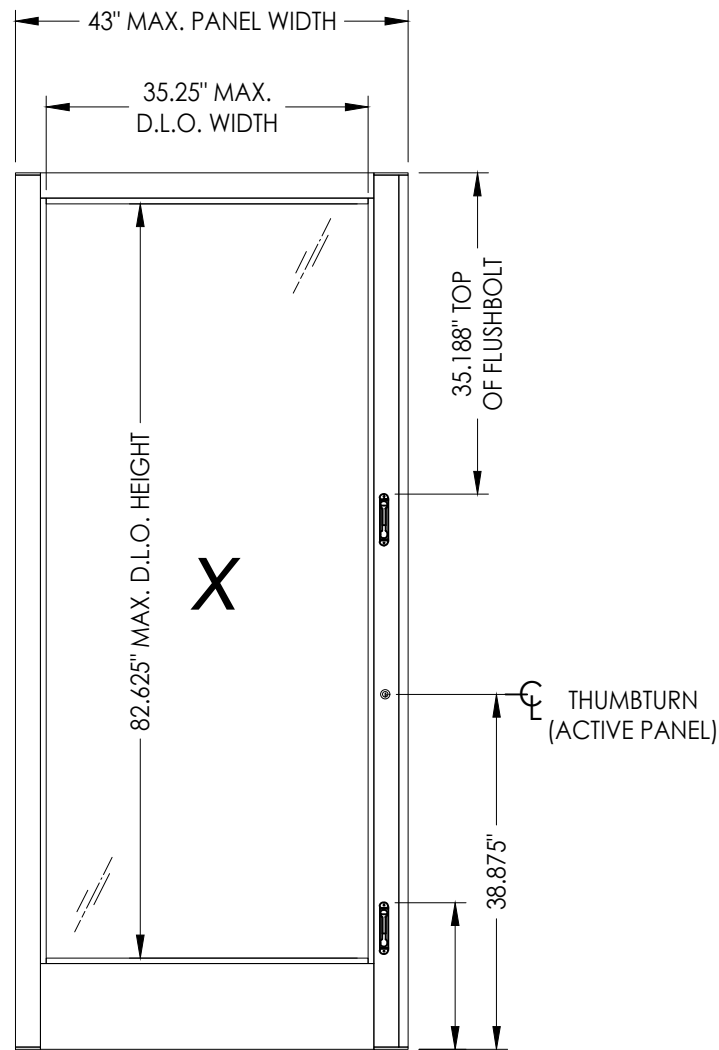

DOOR PANEL

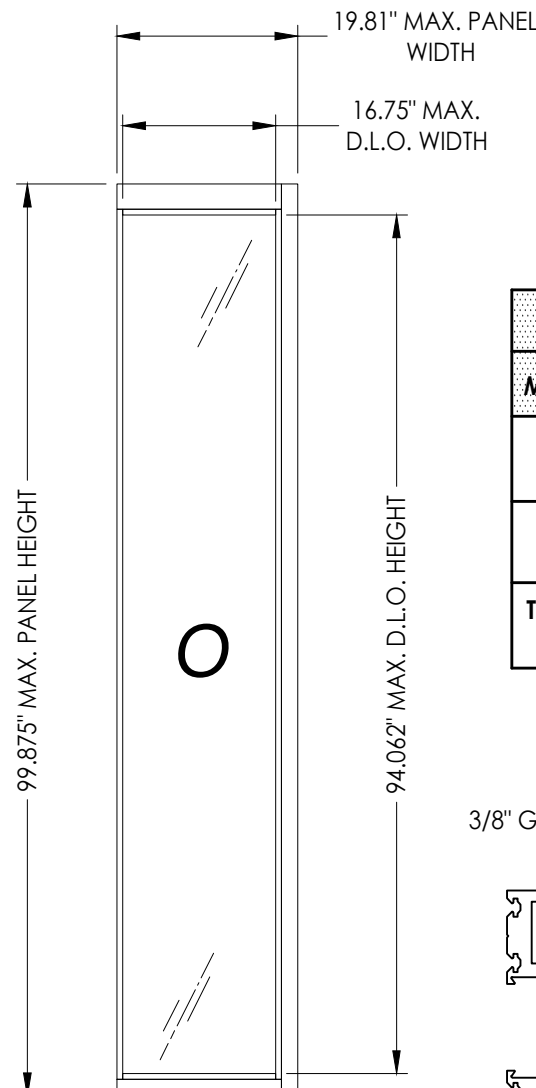

SIDELITE PANEL

HARDWARE TABLE	
MANUFACTURER	MODEL
HOPPE	HOPPE HLS9000 ACTIVE: LEVER w/ 3 pt. LOCK
ADAMS RITE	ACTIVE: THUMBTURN & KEYED CYLINDER MS+ 1890 SERIES DEADBOLT
TERRY HINGE & HARDWARE	ACTIVE: FLUSHBOLTS

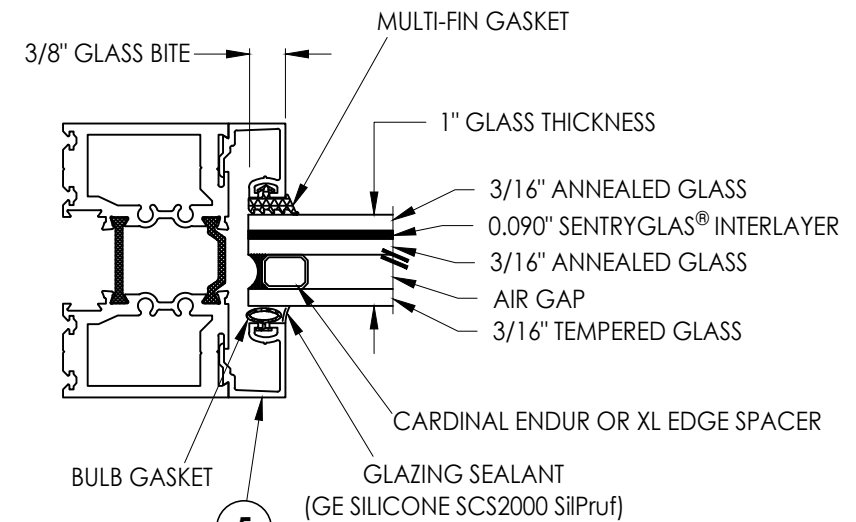

**G1** GLAZING DETAIL

Documents Prepared By: Lyndon F. Schmidt P.E. No. 43409		<b>RW</b> BUILDING CONSULTANTS, INC. P.O. Box 230, Valrico, FL 33595 Phone No.: 813.659.9197 FBPE Registry No. 9813	
PRODUCT:	THERMA-TRU	PART OR ASSEMBLY:	DOOR, SIDELITE & TRANSOM PANELS & GLAZING DETAILS
NO.	DATE	BY	REVISIONS
DATE: 2/07/24 SCALE: N.T.S. DWG. BY: LFS CHK. BY: RW DRAWING NO.: FL-46173.7 SHEET 2 of 12			

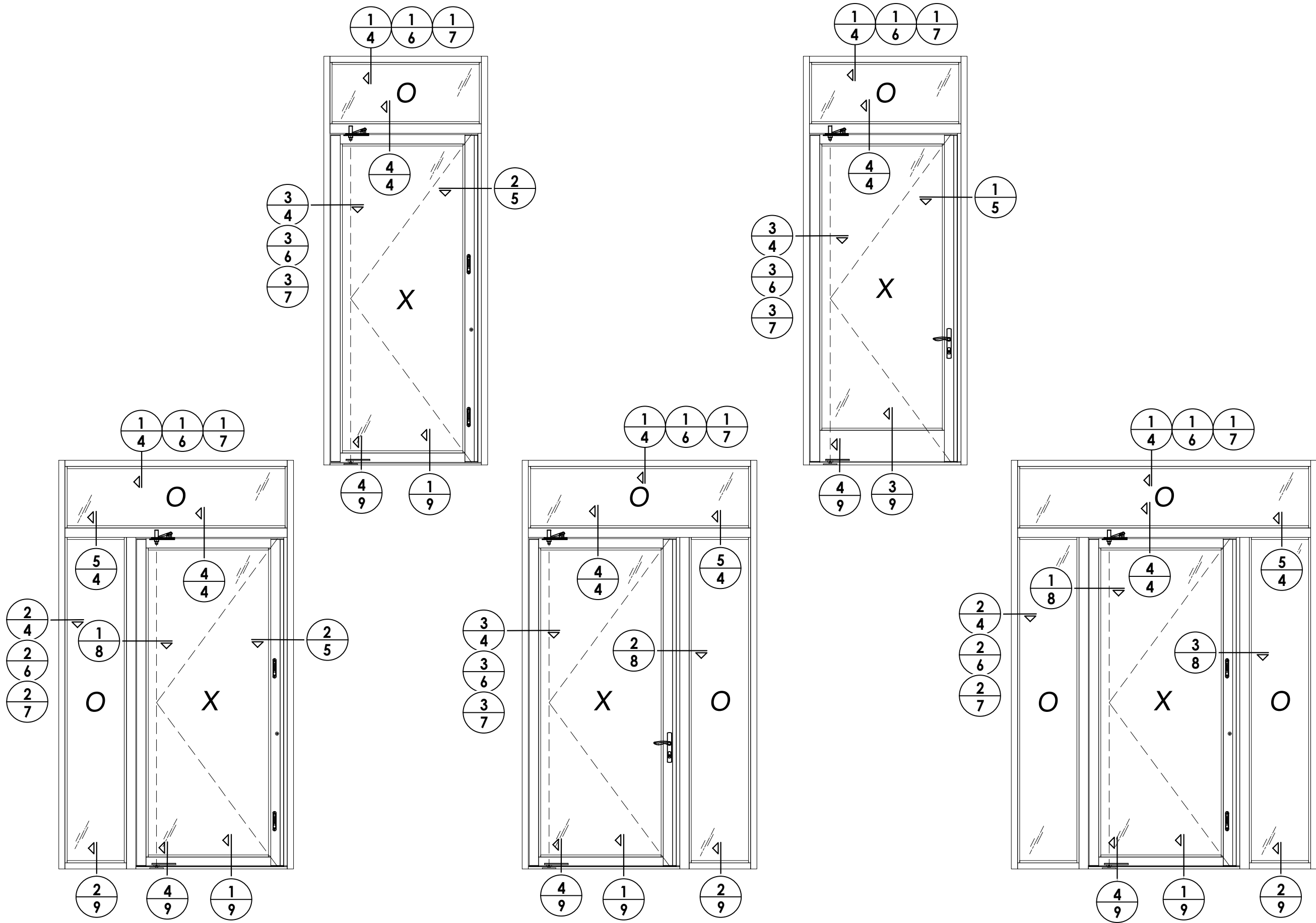

Documents Prepared By:  
Lyndon F. Schmidt  
P.E. No. 43409

**RW** BUILDING CONSULTANTS, INC.  
P.O. Box 230, Vairico, FL 33595  
Phone No.: 813.659.9197  
FBPE Registry No. 9813

PRODUCT: THERMA-TRU

PART OR ASSEMBLY: ELEVATIONS

NO.	DATE	BY	REVISIONS

DATE: 2/07/24  
SCALE: N.T.S.  
DWG. BY: LFS  
CHK. BY: RW  
DRAWING NO.: FL-46173.7  
SHEET 3 OF 12

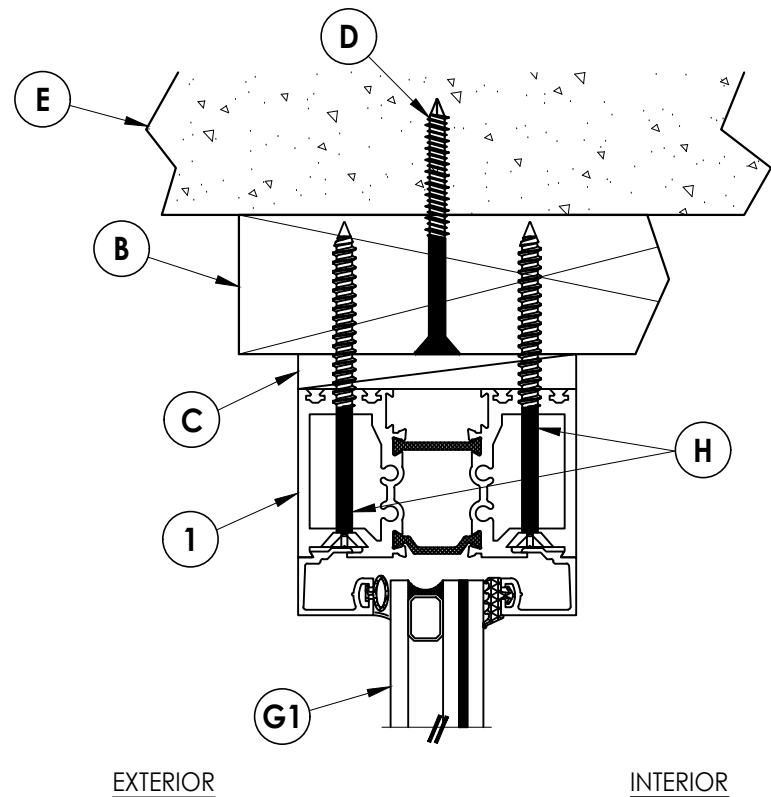

**1** **VERTICAL CROSS SECTION**  
**4** Shown w/ 2X Buck

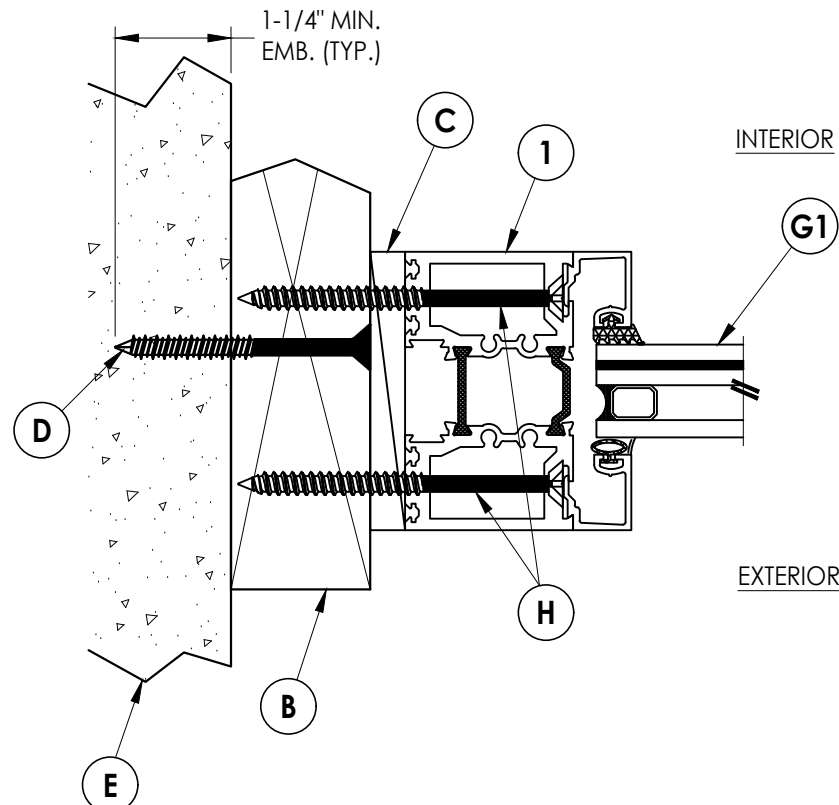

**2** **HORIZONTAL CROSS SECTION**  
**4** Shown w/ 2X Buck

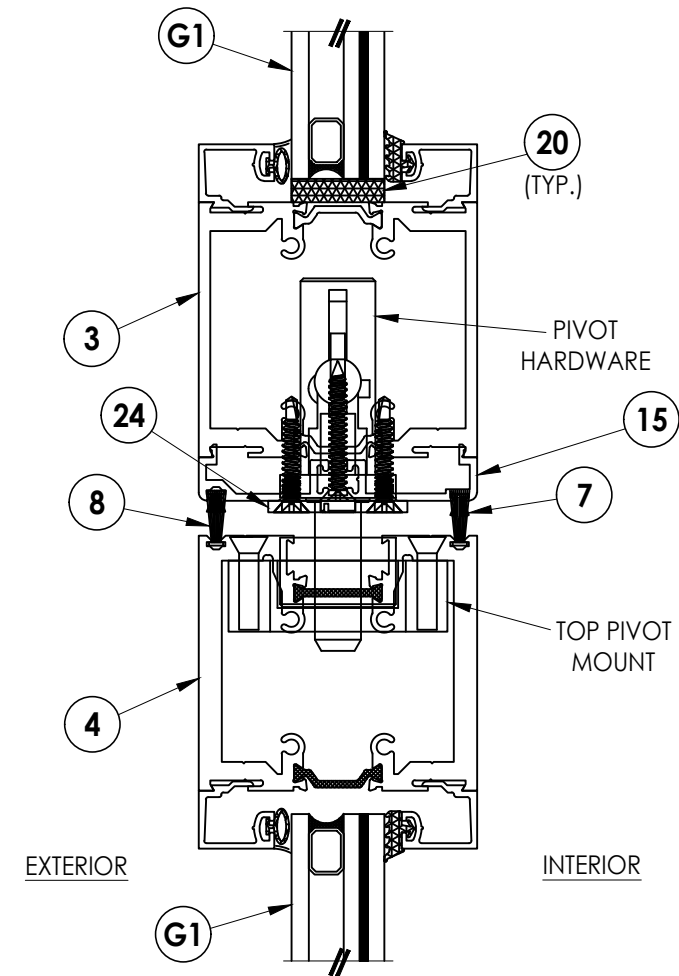

**4** **VERTICAL CROSS SECTION**  
**4**

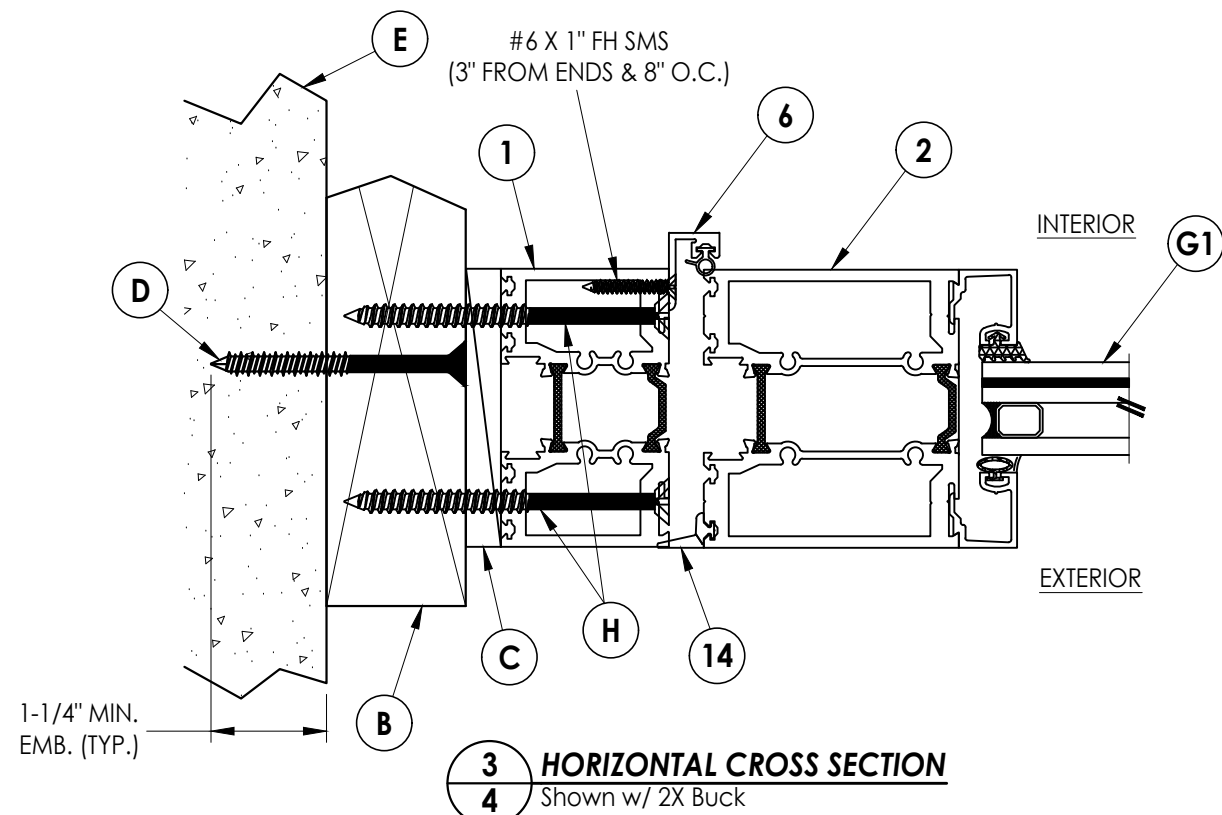

**3** **HORIZONTAL CROSS SECTION**  
**4** Shown w/ 2X Buck

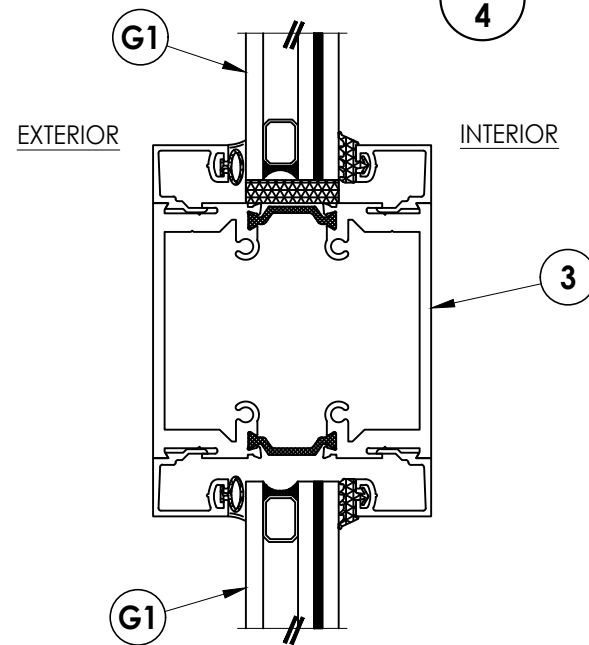

**5** **VERTICAL CROSS SECTION**  
**4**

Documents Prepared By:  
 Lyndon F. Schmidt  
 P.E. No. 43409

**RW** BUILDING CONSULTANTS, INC.  
 P.O. Box 230, Vairico, FL 33595  
 Phone No.: 813.659.9197  
 FBPE Registry No. 9813

PRODUCT: THERMA-TRU  
 PART OR ASSEMBLY:  
 HORIZONTAL & VERTICAL  
 CROSS SECTIONS (2X BUCK)

NO.	DATE	BY	REVISIONS

DATE: 2/07/24  
 SCALE: N.T.S.  
 DWG. BY: LFS  
 CHK. BY: RW  
 DRAWING NO.: FL-46173.7  
 SHEET 4 OF 12

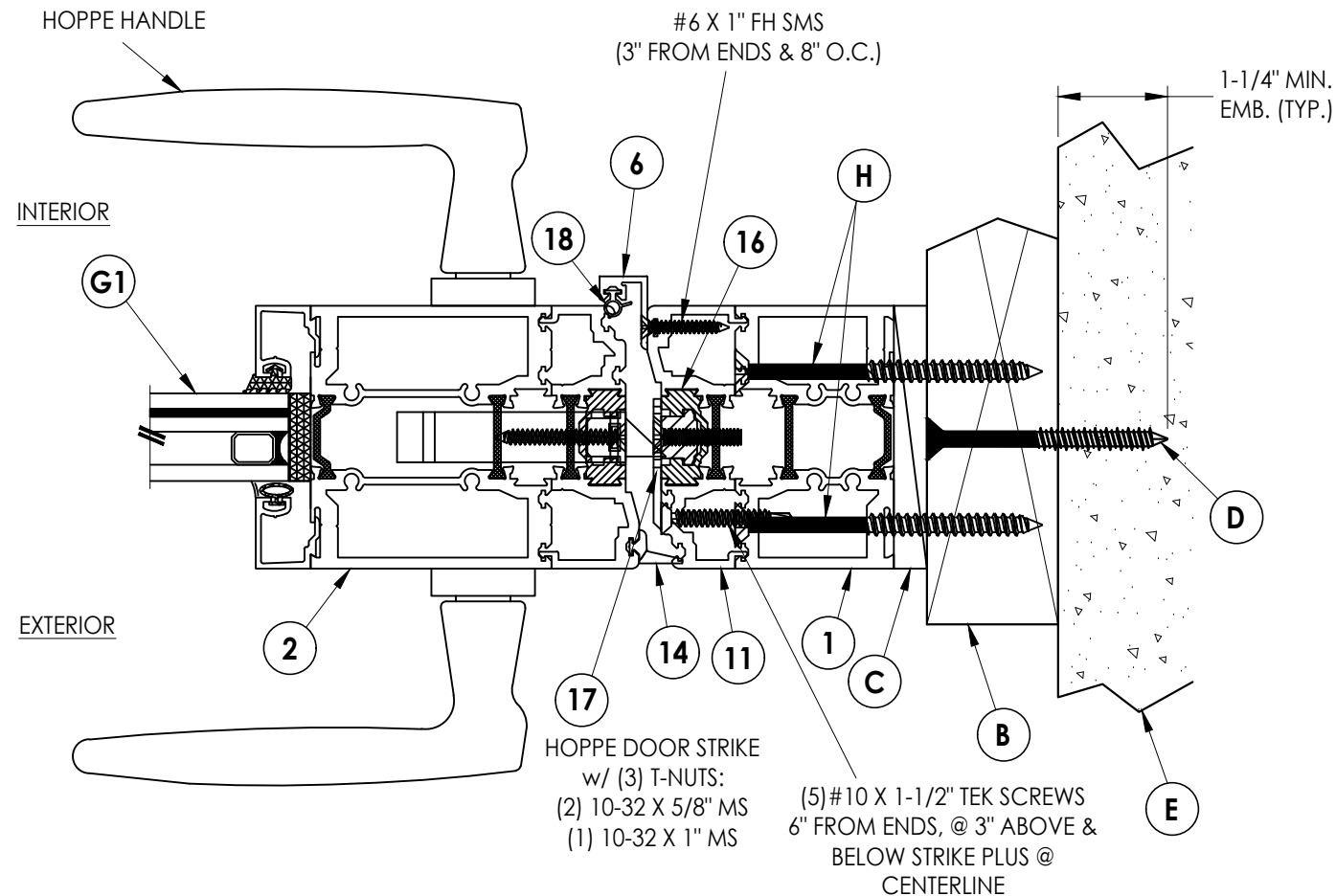

**1 HORIZONTAL CROSS SECTION**  
5 Shown w/ 2X Buck

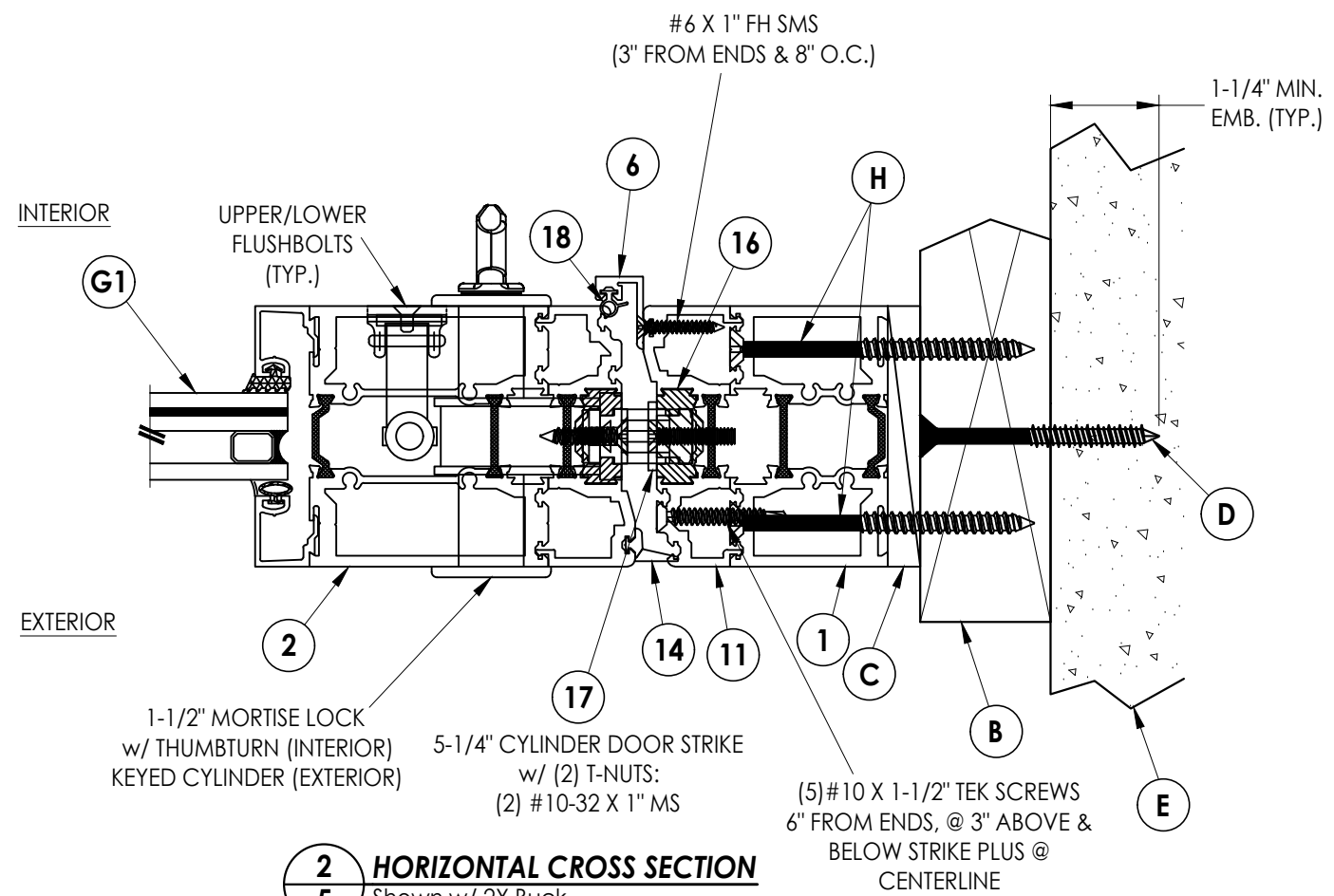

**2 HORIZONTAL CROSS SECTION**  
5 Shown w/ 2X Buck

Documents Prepared By:  
Lyndon F. Schmidt  
P.E. No. 43409

*RW* BUILDING CONSULTANTS, INC.  
P.O. Box 230, Vairico, FL 33595  
Phone No.: 813.659.9197  
FBPE Registry No. 9813

PRODUCT: THERMA-TRU

PART OR ASSEMBLY:  
HORIZONTAL CROSS  
SECTIONS (2X BUCK)

NO.	DATE	BY	REVISIONS

DATE: 2/07/24  
SCALE: N.T.S.  
DWG. BY: LFS  
CHK. BY: RW  
DRAWING NO.:  
FL-46173.7  
SHEET 5 OF 12

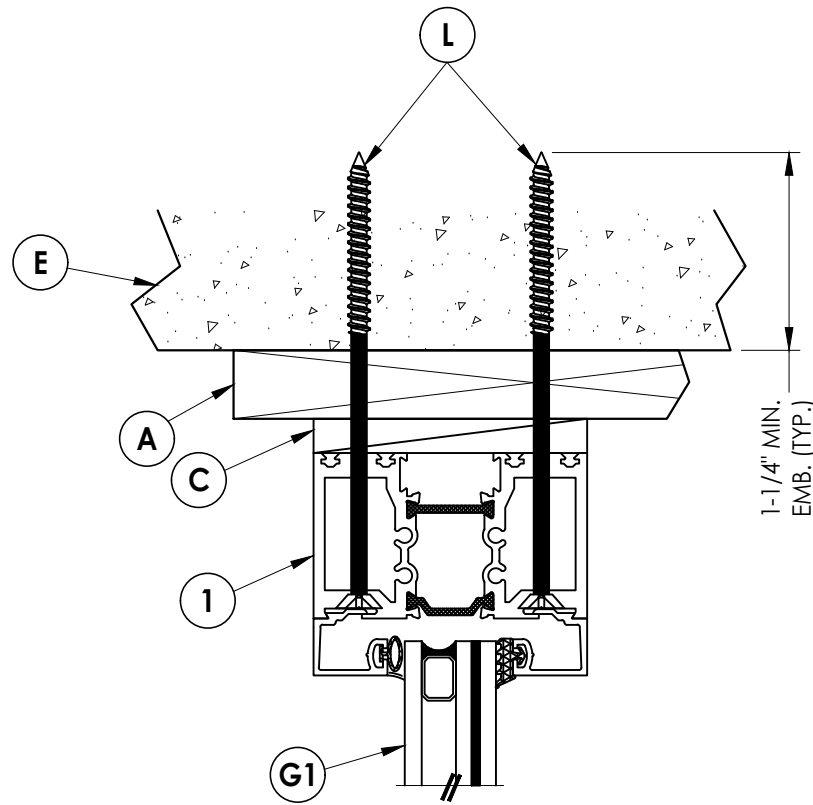

**1** **VERTICAL CROSS SECTION**  
6 Shown w/ 1X Buck

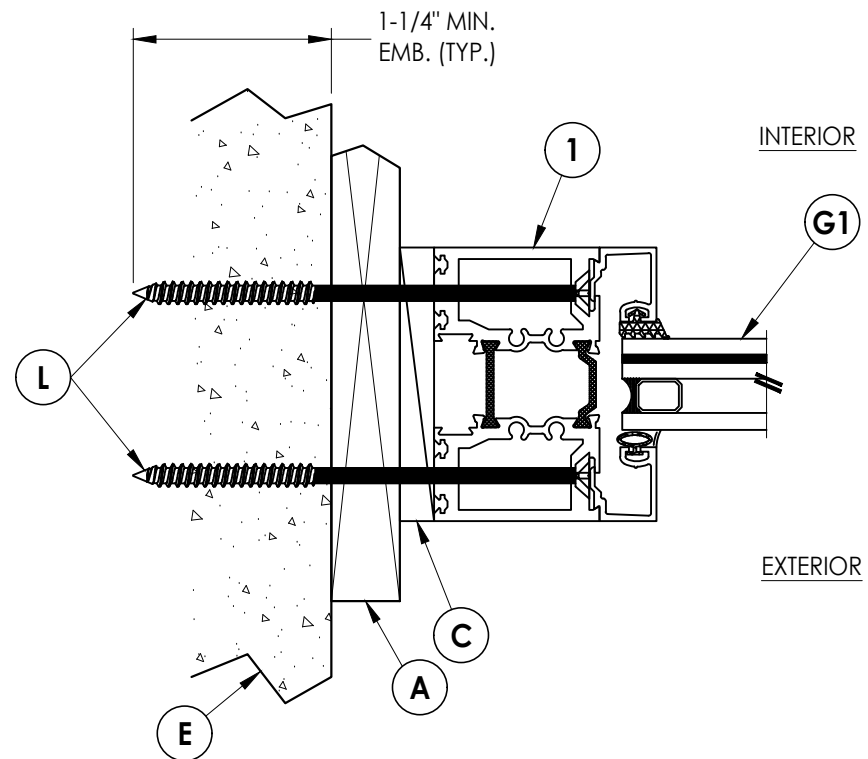

**2** **HORIZONTAL CROSS SECTION**  
6 Shown w/ 1X Buck

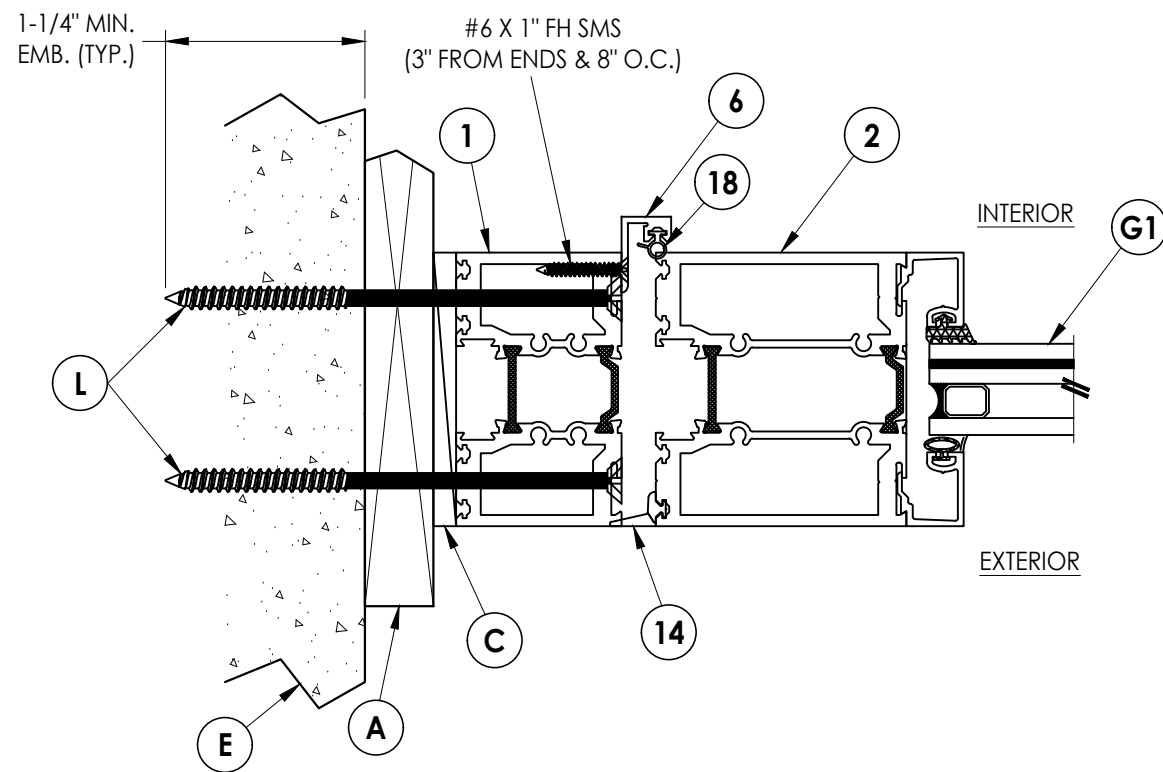

**3** **HORIZONTAL CROSS SECTION**  
6 Shown w/ 1X Buck

Documents Prepared By:  
Lyndon F. Schmidt  
P.E. No. 43409

**RW** BUILDING CONSULTANTS, INC.  
P.O. Box 230, Valrico, FL 33595  
Phone No.: 813.659.9197  
FBPE Registry No. 9813

PRODUCT: THERMA-TRU  
PART OR ASSEMBLY: HORIZONTAL & VERTICAL CROSS SECTIONS (1X BUCK)

NO.	DATE	BY

DATE: 2/07/24  
SCALE: N.T.S.  
DWG. BY: LFS  
CHK. BY: RW  
DRAWING NO.: FL-46173.7  
SHEET 6 OF 12

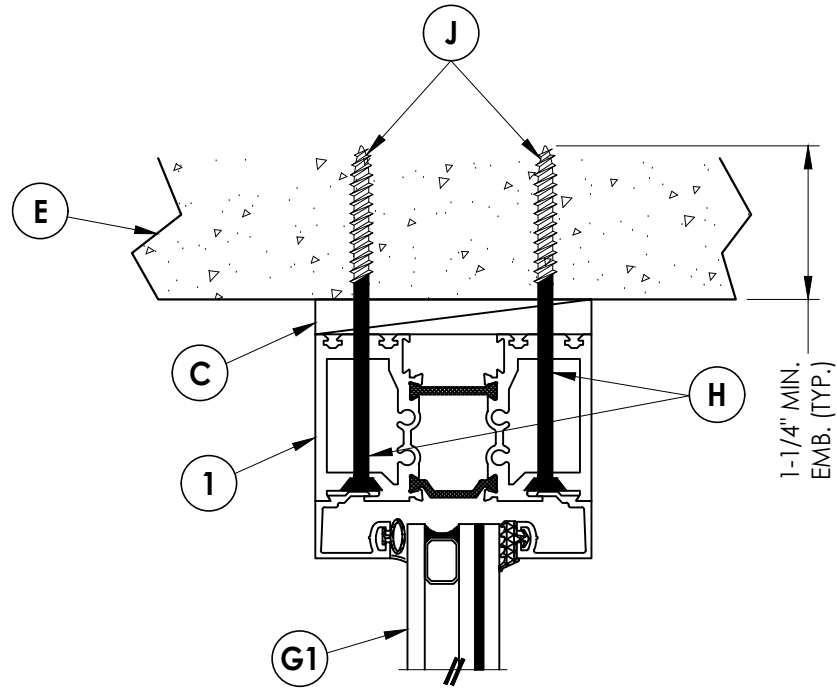

**1** **VERTICAL CROSS SECTION**  
**7** Shown Direct to Masonry

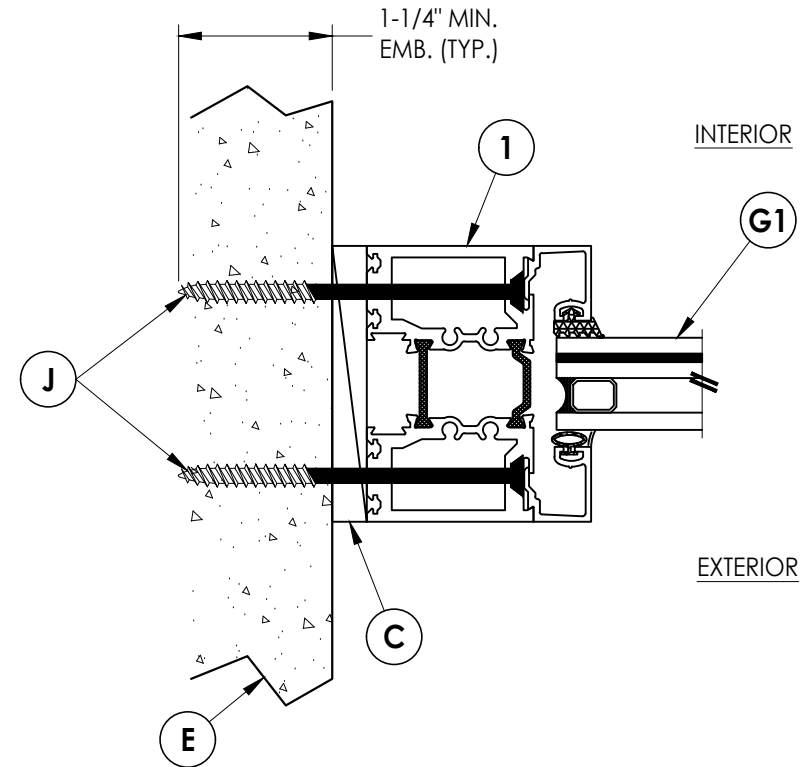

**2** **HORIZONTAL CROSS SECTION**  
**7** Shown Direct to Masonry

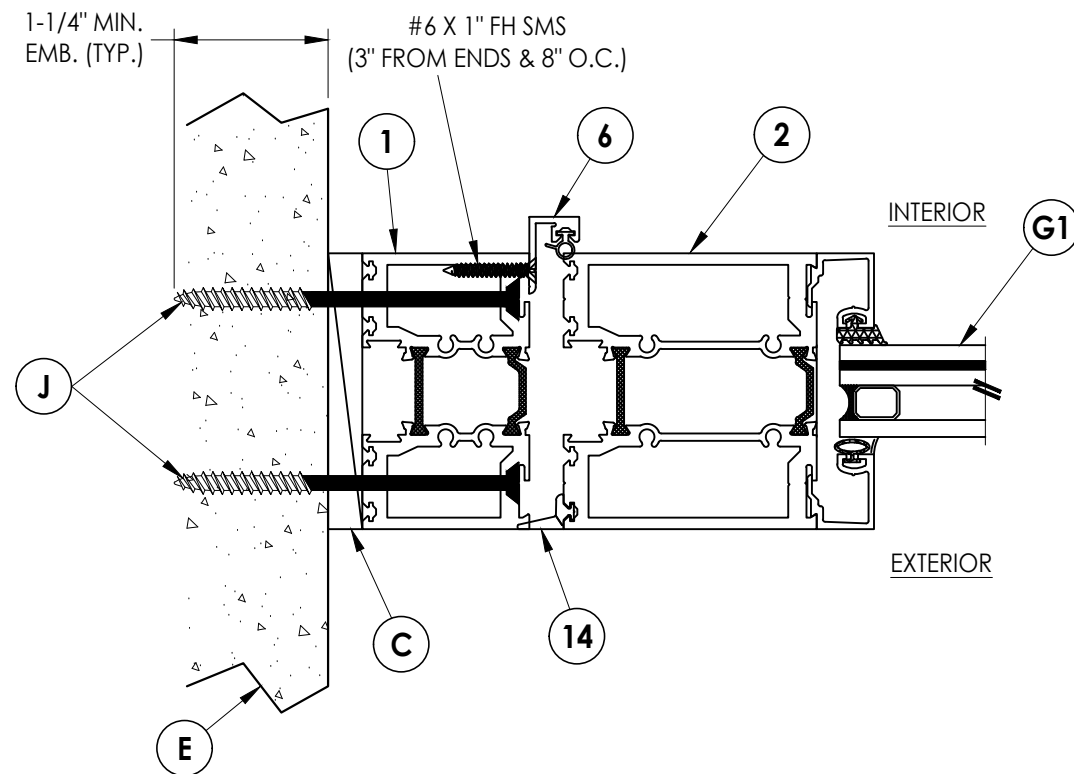

**3** **HORIZONTAL CROSS SECTION**  
**7** Shown Direct to Masonry

Documents Prepared By:  
 Lyndon F. Schmidt  
 P.E. No. 43409

**RW** BUILDING CONSULTANTS, INC.  
 P.O. Box 230, Valrico, FL 33595  
 Phone No.: 813.659.9197  
 FBPE Registry No. 9813

PRODUCT: THERMA-TRU

PART OR ASSEMBLY:  
 HORIZONTAL & VERTICAL CROSS  
 SECTIONS (DIRECT TO MASONRY)

NO.	DATE	BY	REVISIONS

DATE: 2/07/24  
 SCALE: N.T.S.  
 DWG. BY: LFS  
 CHK. BY: RW  
 DRAWING NO.: FL-46173.7  
 SHEET 7 OF 12

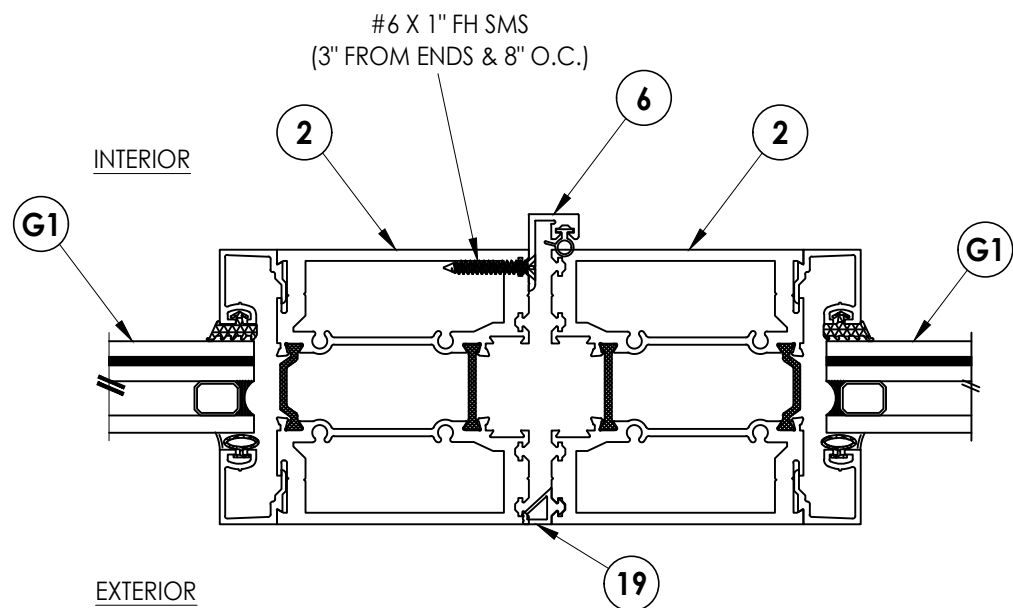

**1**  
**8** HORIZONTAL CROSS SECTION

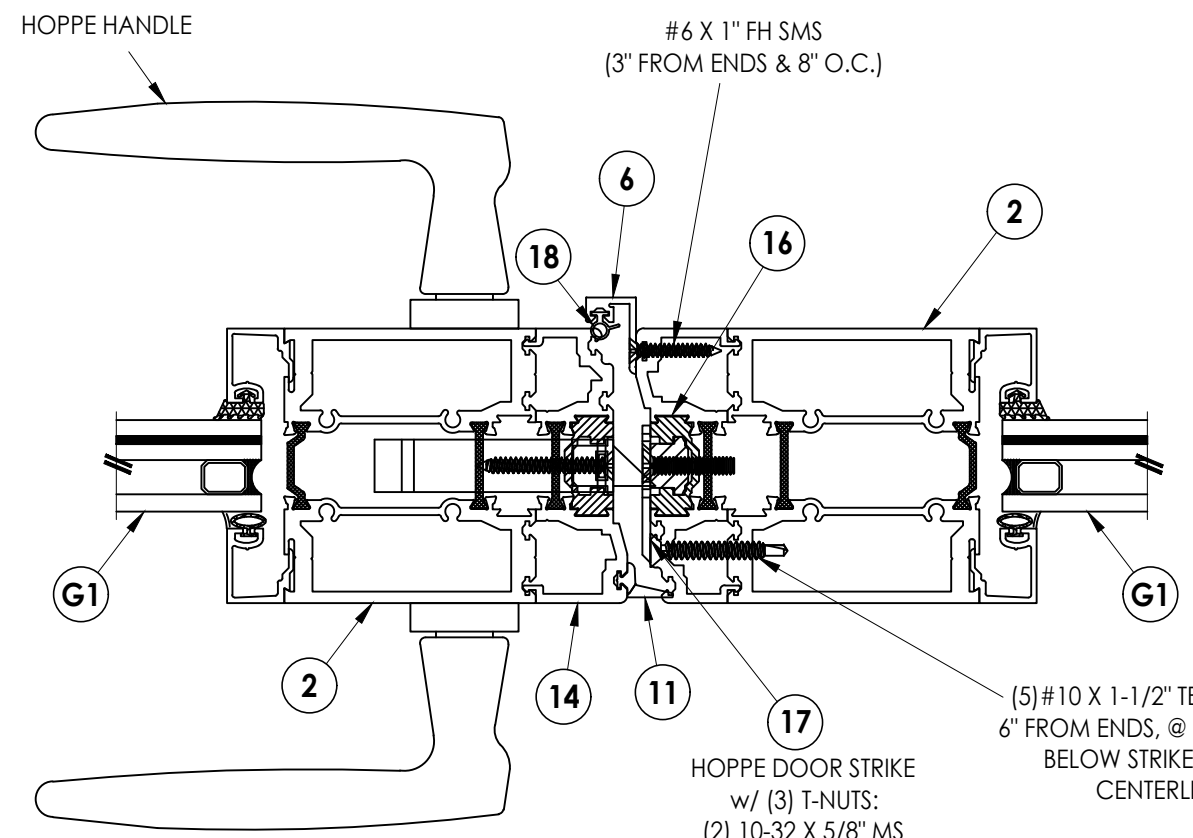

**2**  
**8** HORIZONTAL CROSS SECTION

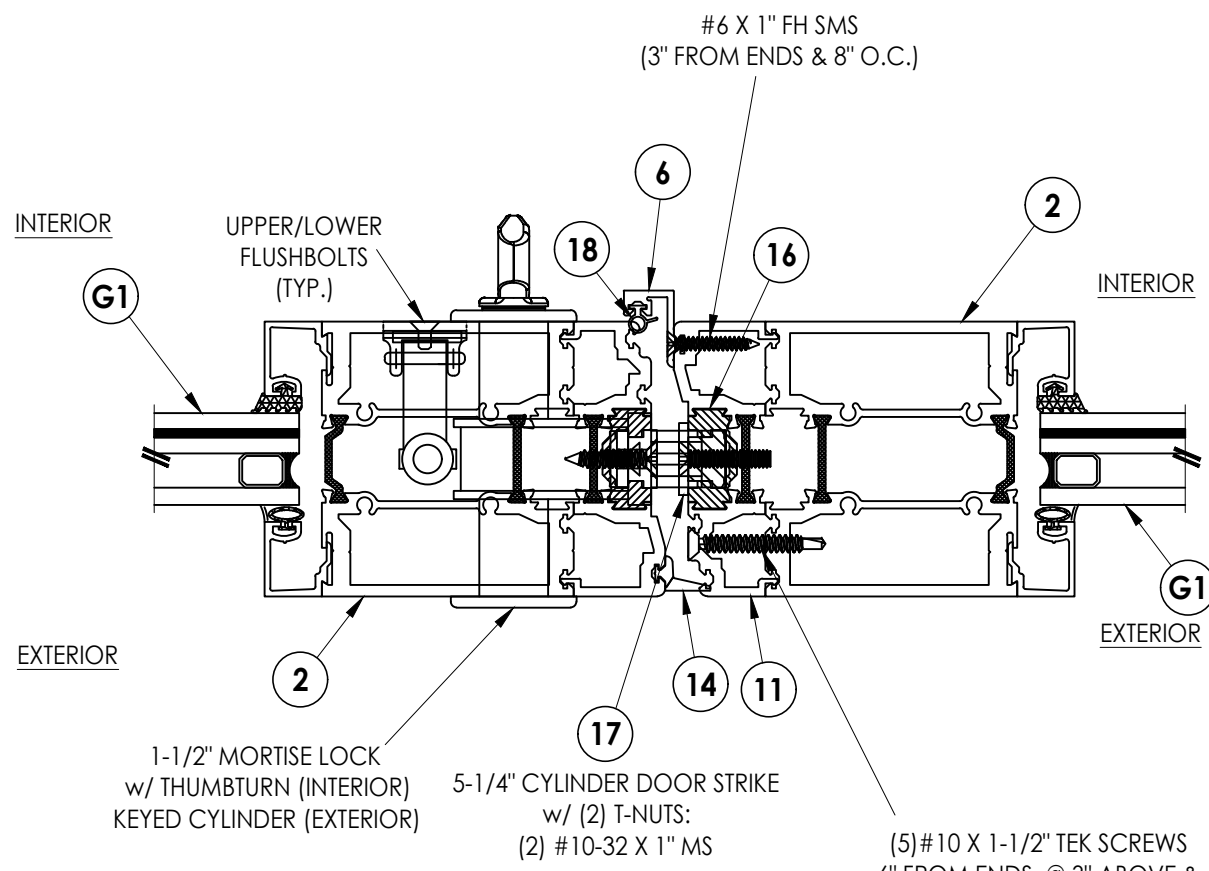

**3**  
**8** HORIZONTAL CROSS SECTION

Documents Prepared By:  
Lyndon F. Schmidt  
P.E. No. 43409

**RW** BUILDING CONSULTANTS, INC.  
P.O. Box 230, Valrico, FL 33595  
Phone No.: 813.659.9197  
FBPE Registry No. 9813

PRODUCT:	Therma-TRU
PART OR ASSEMBLY:	HORIZONTAL CROSS SECTIONS

NO.	DATE	BY	REVISIONS

DATE:	2/07/24
SCALE:	N.T.S.
DWG. BY:	LFS
CHK. BY:	RW
DRAWING NO.:	FL-46173.7
SHEET	8 OF 12



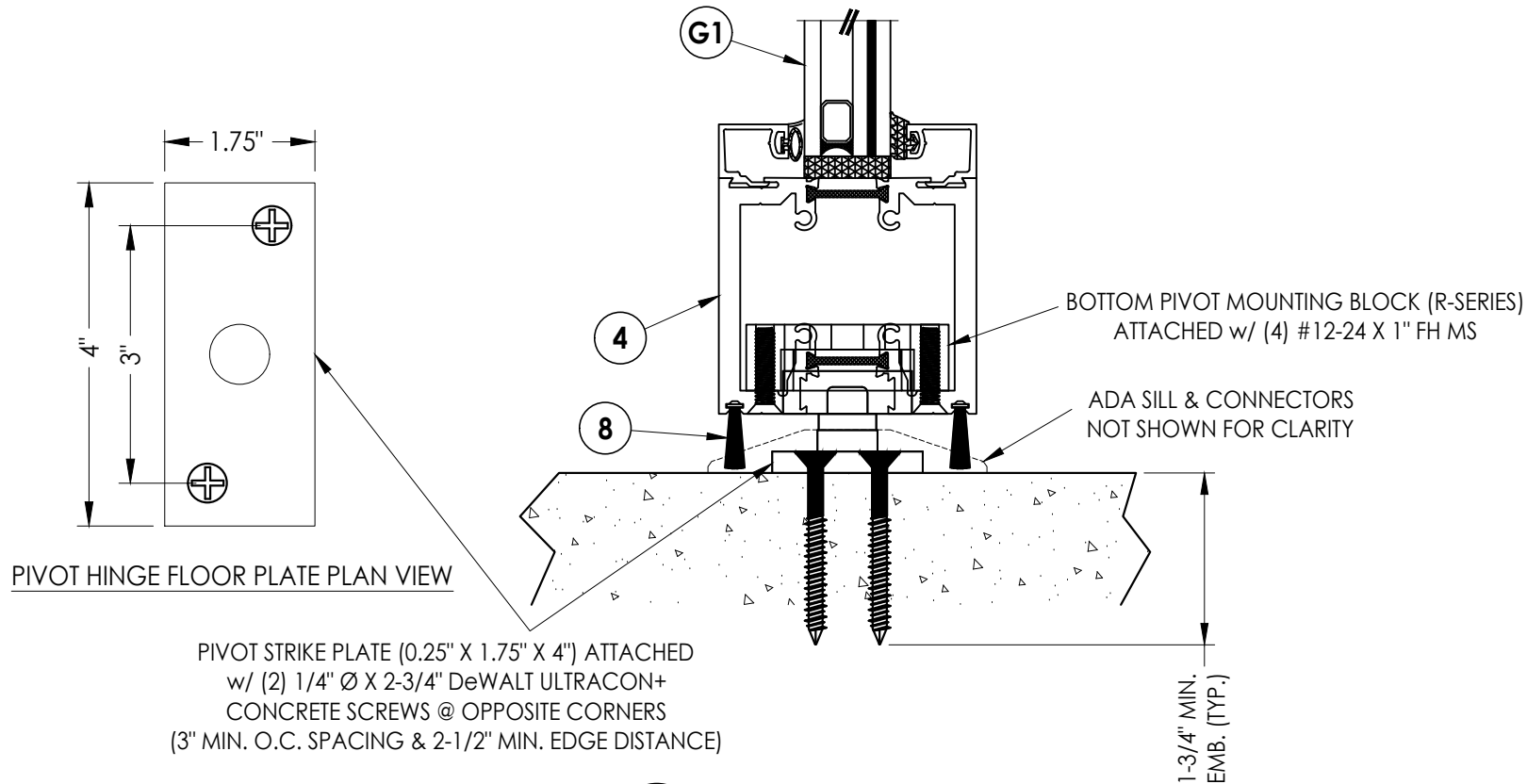
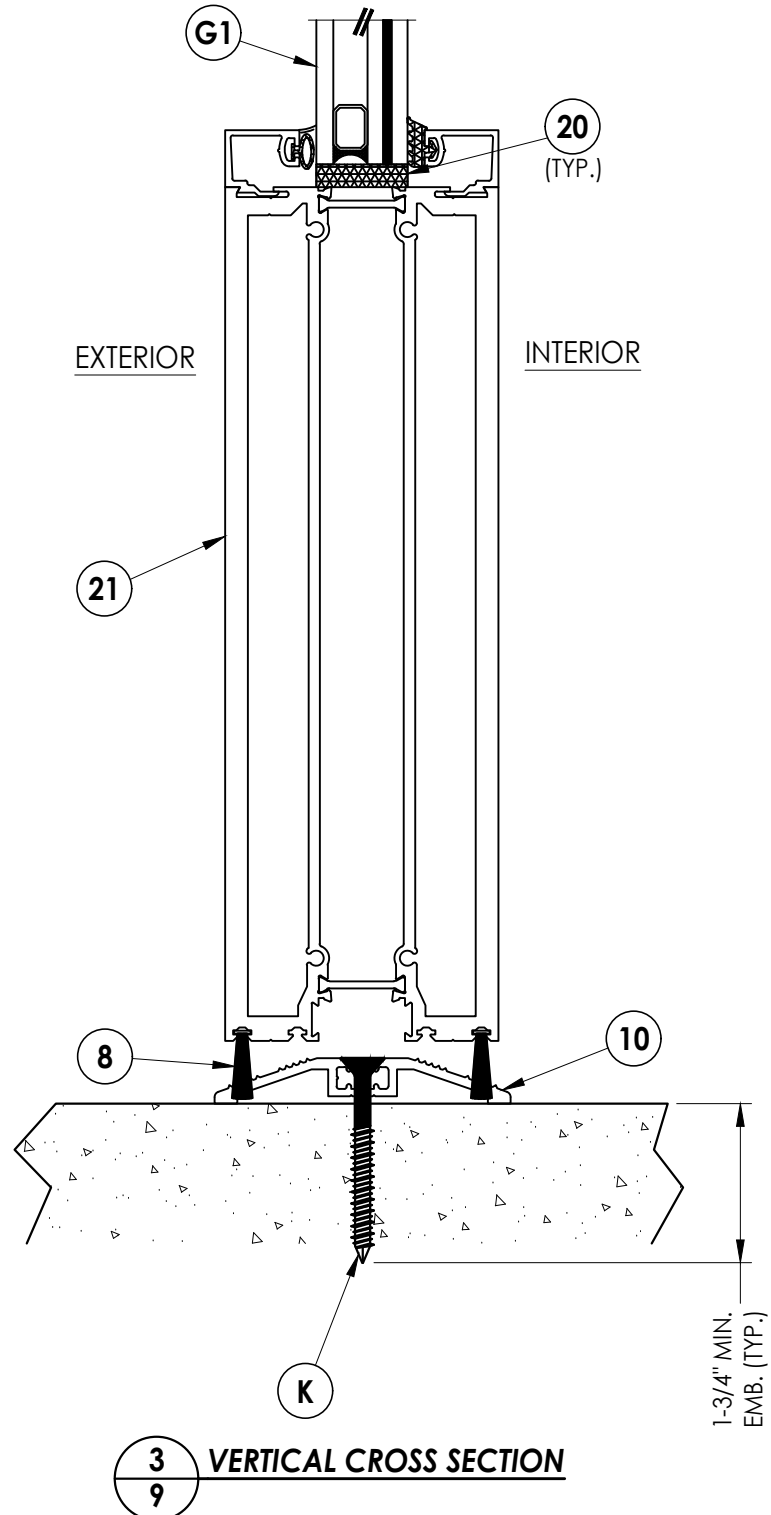
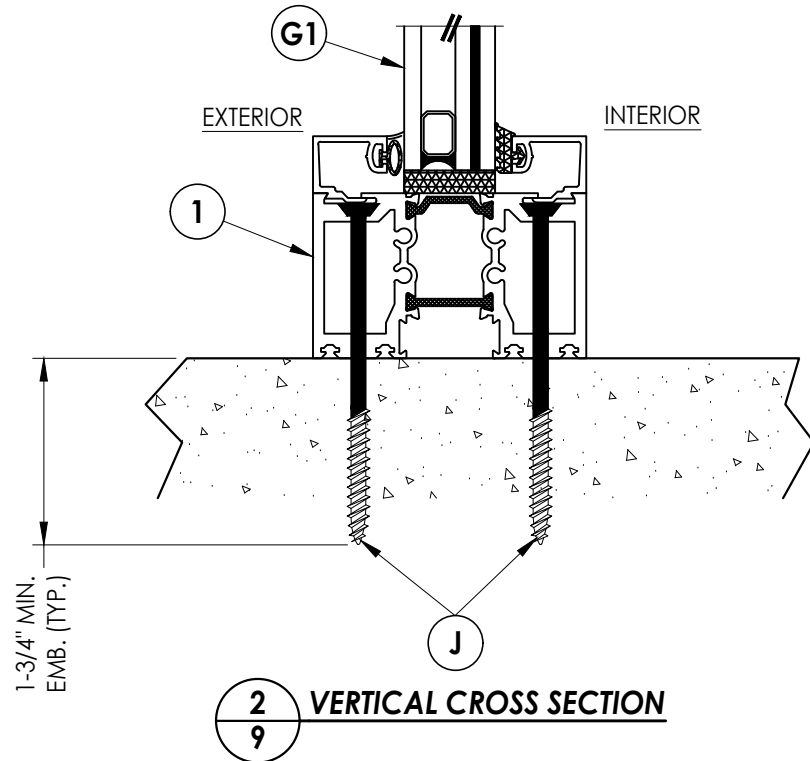
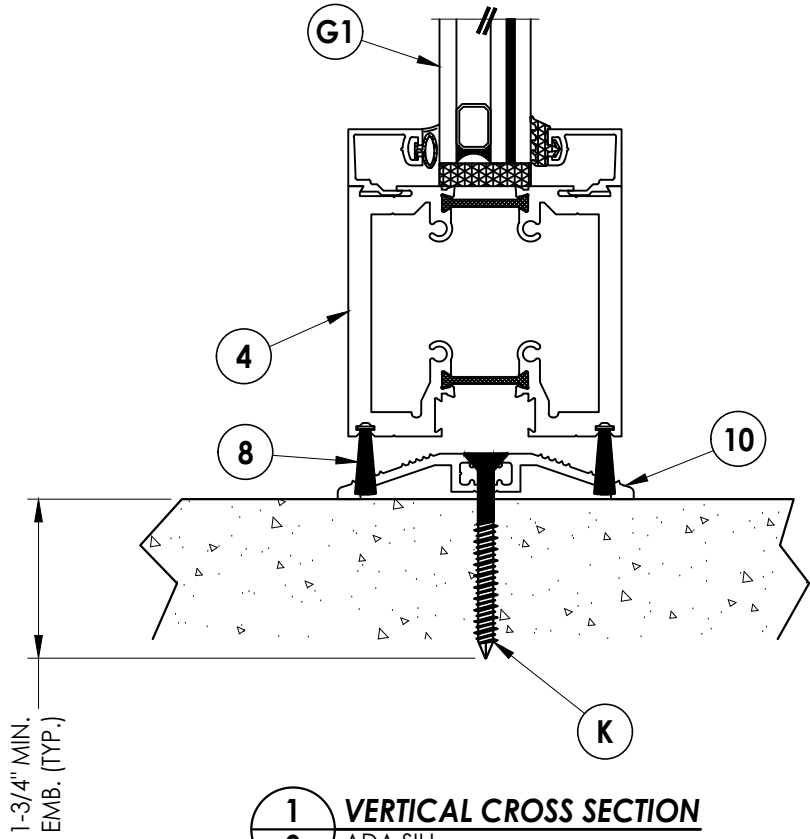

Documents Prepared By:  
Lyndon F. Schmidt  
P.E. No. 43409

**RW** BUILDING CONSULTANTS, INC.  
P.O. Box 230, Valrico, FL 33595  
Phone No.: 813.659.9197  
FBPE Registry No. 9813

PRODUCT: THERMA-TRU

PART OR ASSEMBLY:  
VERTICAL CROSS SECTIONS

NO.	DATE	BY

DATE: 2/07/24

SCALE: N.T.S.

DWG. BY: JK

CHK. BY: RW

DRAWING NO.:

FL-46173.7

SHEET 9 OF 12

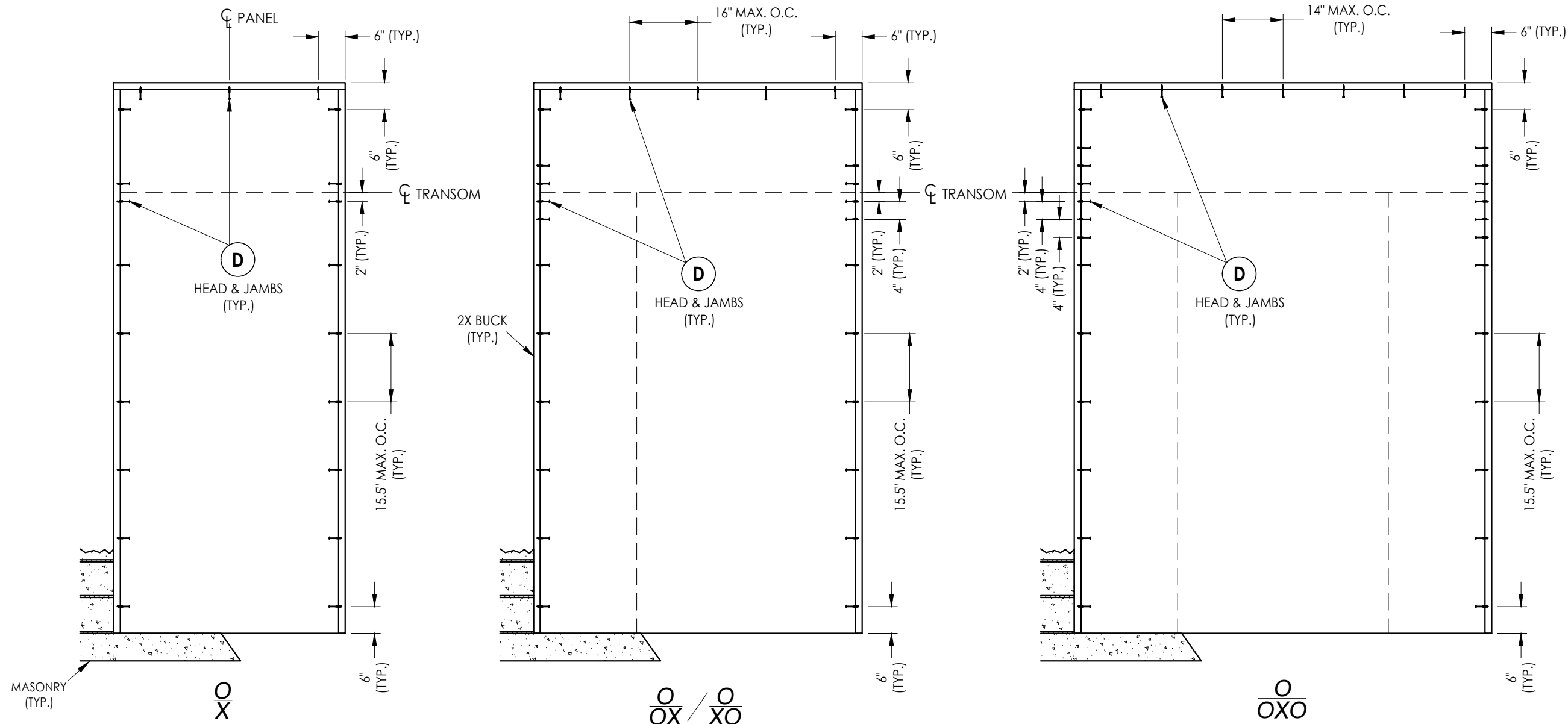

### 2X BUCK ANCHORING

**CONCRETE ANCHOR NOTES:**

1. Concrete anchor locations at the corners may be adjusted to maintain the min. edge distance to mortar joints.
2. Concrete anchor locations noted as "MAX. ON CENTER" must be adjusted to maintain the min. edge distance to mortar joints, additional concrete anchors may be required to ensure the "MAX. ON CENTER" dimension are not exceeded.
3. Concrete anchor table:

ANCHOR TYPE	ANCHOR SIZE	MIN. EMBEDMENT	MIN. CLEARANCE TO MASONRY EDGE	MIN. CLEARANCE TO ADJACENT ANCHOR
ITW TAPCON®	1/4"	1-1/4" 1-3/4" (SILL)	2"	4"
DeWALT ULTRACON®	1/4"	1-1/4" 1-3/4" (SILL)	1"	4"

**WOOD SCREW INSTALLATION NOTES:**

1. Maintain a minimum 5/8" edge distance, 1" end distance, & 1" o.c. spacing of wood screws to prevent the splitting of wood.

Documents Prepared By:  
Lyndon F. Schmidt  
P.E. No. 43409

**RW** BUILDING CONSULTANTS, INC.  
P.O. Box 230, Vairico, FL 33595  
Phone No.: 813.659.9197  
FBPE Registry No. 9813

PRODUCT:	THERMA TRU
PART OR ASSEMBLY:	BUCK ANCHORING

NO.	DATE	BY

DATE:	2/07/24
SCALE:	N.T.S.
DWG. BY:	JK
CHK. BY:	RW
DRAWING NO.:	FL-46173.7
SHEET	10 OF 12

NOTE: ALL ANCHORS SHOWN ARE STAGGERED EXCEPT FOR THE ADA SILL ANCHORS (SEE CROSS-SECTIONS)

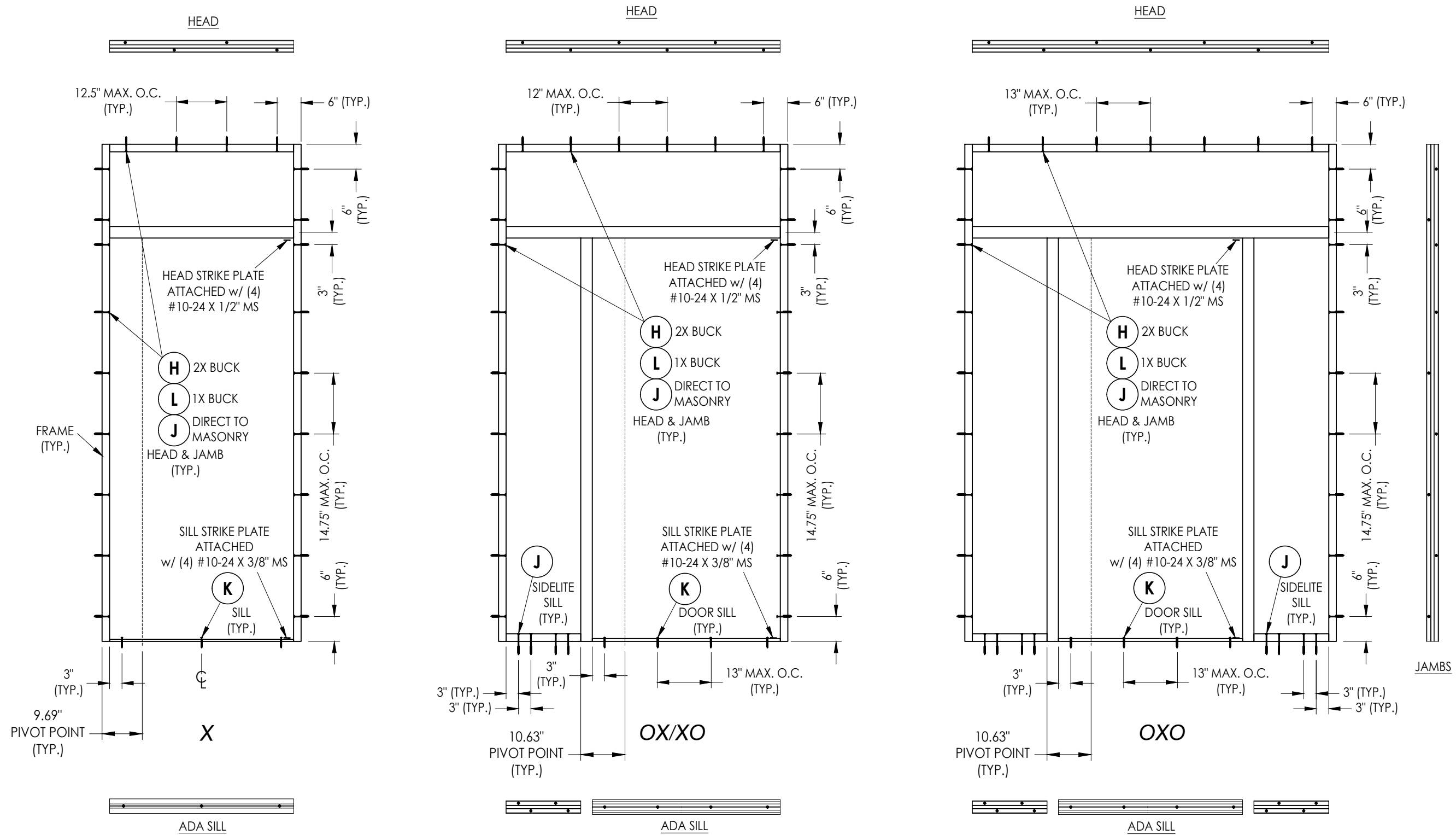

**FRAME ANCHORING**

Documents Prepared By:  
Lyndon F. Schmidt  
P.E. No. 43409

**RW** BUILDING CONSULTANTS, INC.  
P.O. Box 230, Valrico, FL 33595  
Phone No.: 813.659.9197  
FBPE Registry No. 9813

PRODUCT:	THERMA TRU
PART OR ASSEMBLY:	FRAME ANCHORING

NO.	DATE	BY

DATE:	2/07/24
SCALE:	N.T.S.
DWG. BY:	JK
CHK. BY:	RW
DRAWING NO.:	FL-46173.7
SHEET	11 OF 12

**BILL OF MATERIALS**

ITEM	DESCRIPTION	MATERIAL
A	1X BUCK (SG >= 0.42)	WOOD
B	2X BUCK (SG >= 0.42)	WOOD
C	3/8" MAX. SHIM SPACE	-
D	1/4" X 2-3/4" PFH DeWALT OR ITW CONCRETE SCREW	STEEL
E	MASONRY - 3,000 PSI MIN. CONCRETE CONFORMING TO ACI 301 OR HOLLOW BLOCK CONFORMING TO ASTM C90	CONCRETE
H	#14 X 3-1/2" FH SMS (1-1/4" MIN. EMBEDMENT)	S.S.
J	1/4" X 3-3/4" PFH DeWALT OR ITW CONCRETE SCREW	STEEL
K	1/4" X 2-1/4" PFH DeWALT OR ITW CONCRETE SCREW	STEEL
L	1/4" X 5" PFH DeWALT OR ITW CONCRETE SCREW	STEEL
1	LT NARROW FRAME	6063-T6 ALUM
2	LT FRAME	6063-T6 ALUM
3	MULLION	6063-T6 ALUM
4	PIVOT FRAME	6063-T6 ALUM
5	1/4" GLASS STOP	6063-T6 ALUM
6	SLIDE-IN DOOR STOP	6063-T5 ALUM
7	FELT WEATHERSTRIP	-
8	3/4" BRUSH WEATHERSTRIP	-
10	ADA SILL	6063-T5 ALUM
11	SWING DOOR ADAPTER	6063-T6 ALUM
14	DOOR SWEEP FOAM GASKET	-
15	DOOR ADAPTER	6063-T6 ALUM
16	16mm EUROGROOVE	-
17	HOPPE DOOR STRIKE	S.S.
18	BULB GASKET	-
19	DOOR GASKET	-
20	SETTING BLOCK	-
21	DOOR BOTTOM PANEL	6063-T5 ALUM
24	STRIKE PLATE (@ HEAD)	S.S.

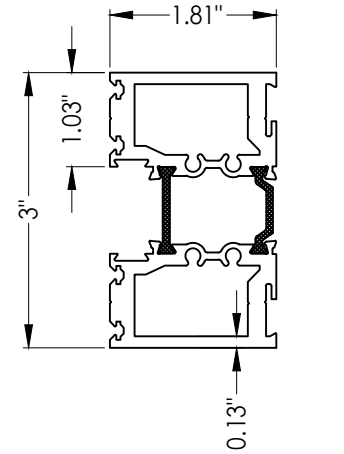

**1 LT NARROW FRAME**

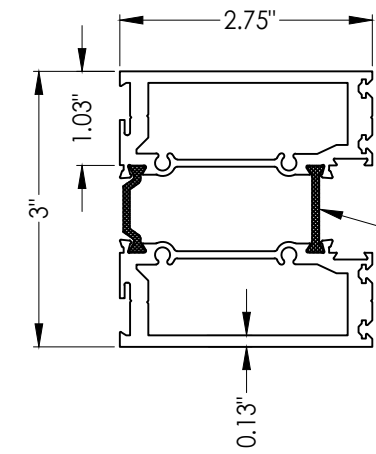

**2 LT FRAME**

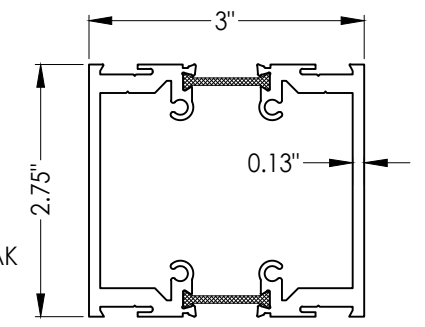

**3 MULLION**

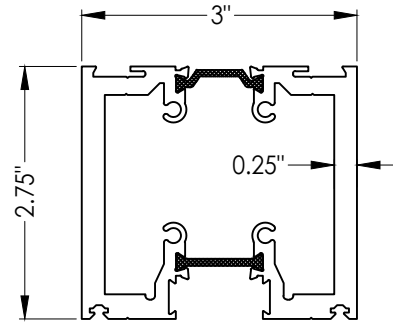

**4 PIVOT FRAME**

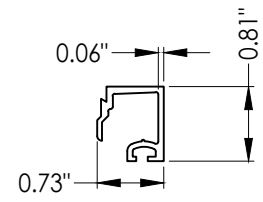

**5 1/4" GLASS STOP**

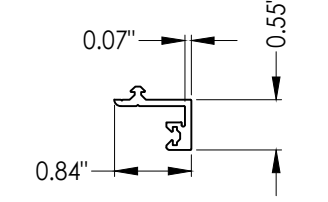

**6 SLIDE-IN DOOR STOP**

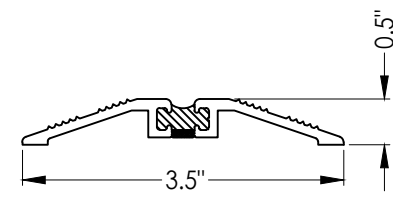

**10 ADA SILL**

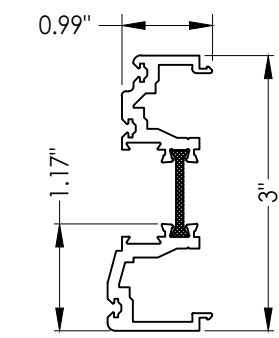

**11 SWING DOOR ADAPTER**

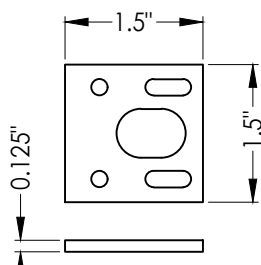

**24 STRIKE PLATE @ HEAD**

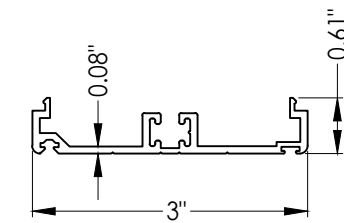

**15 DOOR ADAPTER**

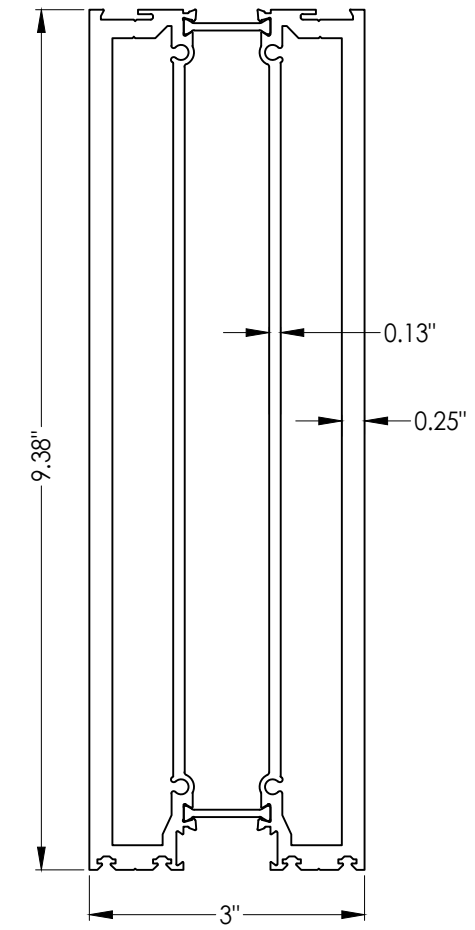

**18 DOOR BOTTOM PANEL**

THERMAL BREAK (TYP.)

Documents Prepared By:  
Lyndon F. Schmidt  
P.E. No. 43409

**RW** BUILDING CONSULTANTS, INC.  
P.O. Box 230, Valrico, FL 33595  
Phone No.: 813.659.9197  
FBPE Registry No. 9813

PRODUCT: THERMA TRU  
PART OR ASSEMBLY: BILL OF MATERIAL & COMPONENTS

NO.	DATE	BY	REVISIONS

DATE: 2/07/24  
SCALE: N.T.S.  
DWG. BY: JK  
CHK. BY: RW  
DRAWING NO.: FL-46173.7  
SHEET 12 OF 12